

# Tablesaw Miter Jig

To build this jig, first place one miter-slot guide into each slot on your saw table. Align the 1/2" plywood base on top of the guide, long edges perpendicular to the miter slots. With the plywood resting on the table saw surface, drill 5/32" shank holes through the plywood and into the guides just far enough to mark their positions. Remove the plywood and guides and drill 7/64" pilot holes through the guides. Reposition these pieces on the table saw, and attach the guides with countersunk #8x1" brass wood screws. Drive the screws about halfway through the guides, and lift the assembly off the table. Drive the screws completely, and sand off their protruding tips. Again, place the jig onto the table saw surface, turn on the saw, and cut a kerf about halfway across the width of the plywood.

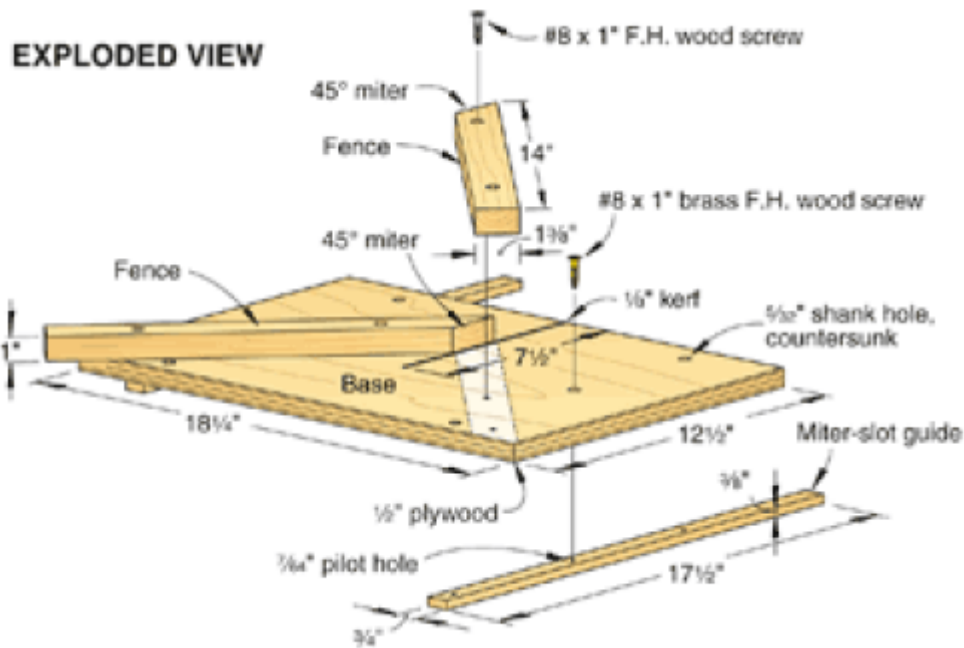

The key to this jig's accuracy is installing the miter fences precisely at 90°. The drawings below take you through the first two alignment steps. Use this process to temporarily attach each fence with two #8x1" screws. Test the fences for accuracy by cutting four sample pieces, each about 1" wide and 4" long. Hold them together with a rubber band and check for any gaps at the miters. Adjust the position of the fences as necessary by tapping them with a hammer. Once you're satisfied that the fences are in exactly the right positions, attach each of them with two #8x1" screws. Finally, to help hold your workpieces steady against the fences during cuts, attach adhesive-backed 100-grit sandpaper to the fence faces where shown in the photo above.



Installing the Miter Fence

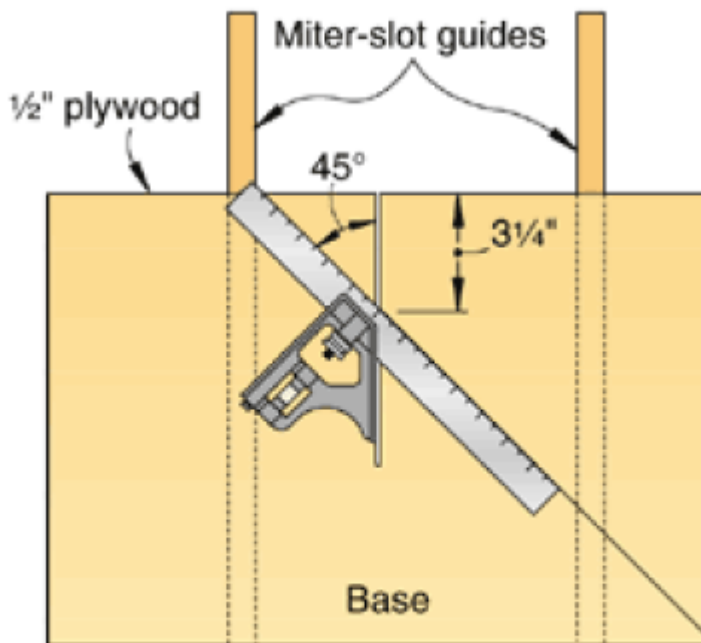

**Step 1**  
Align combination square with saw kerf. Mark a 45° line as shown.

